

B02EAD301



M6x10

X8

B02VA4501



M6x16

X12

B022A1801



4x20

X22

B040H0503

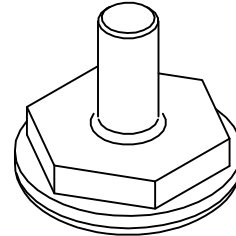

X4

B233B11XX

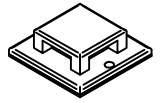

X4

B233B12XX

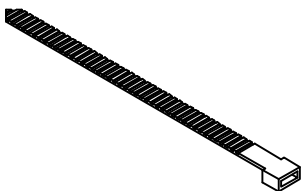

X6

B021A0401



3x20

X8

B021AD601

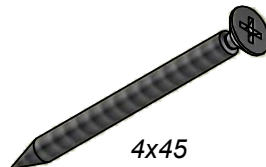

4x45

X2

B021A2101



4x35

X2

X2

X2

X2

X2

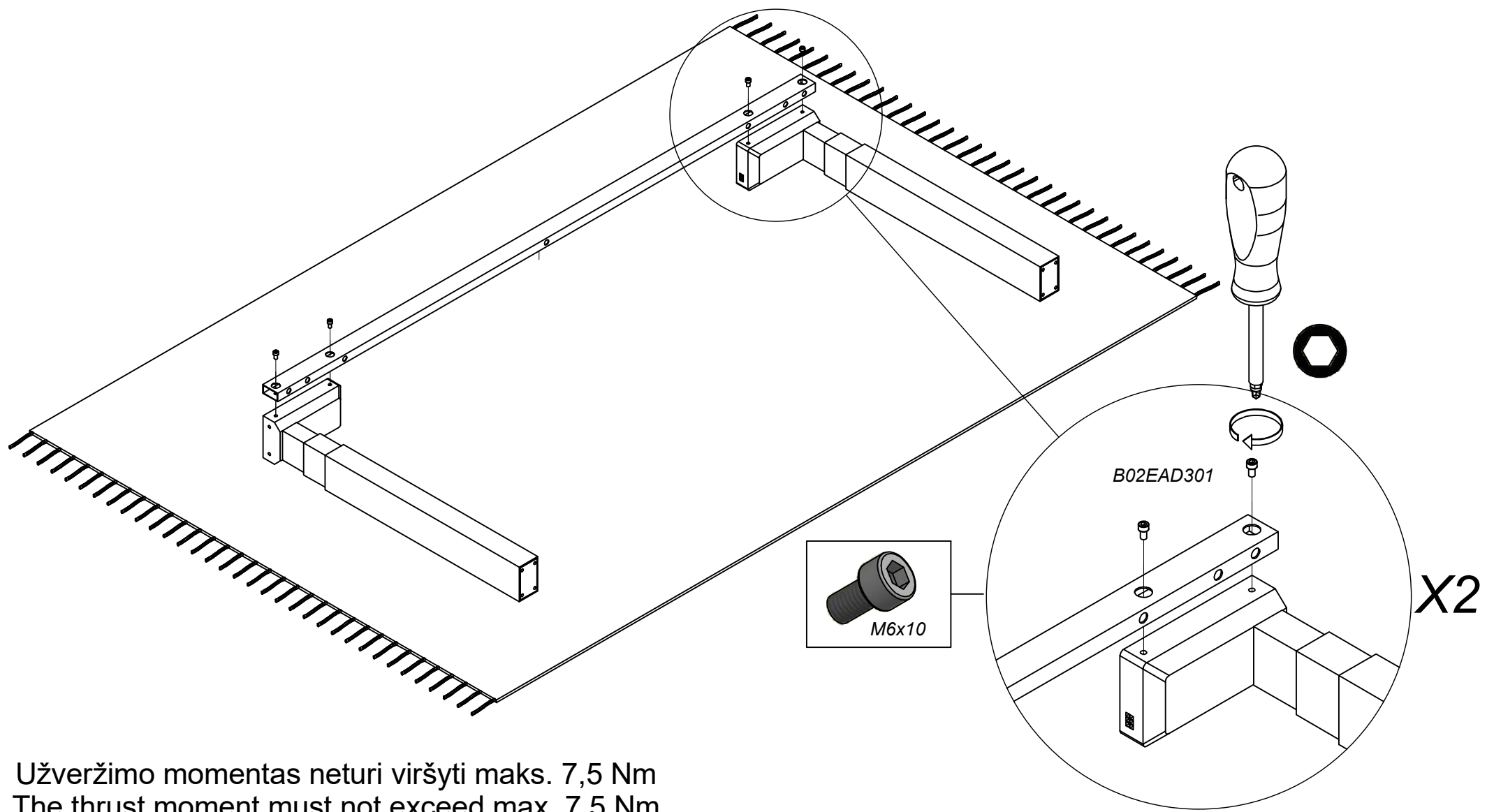

Užveržimo momentas neturi viršyti maks. 7,5 Nm  
 The thrust moment must not exceed max. 7,5 Nm

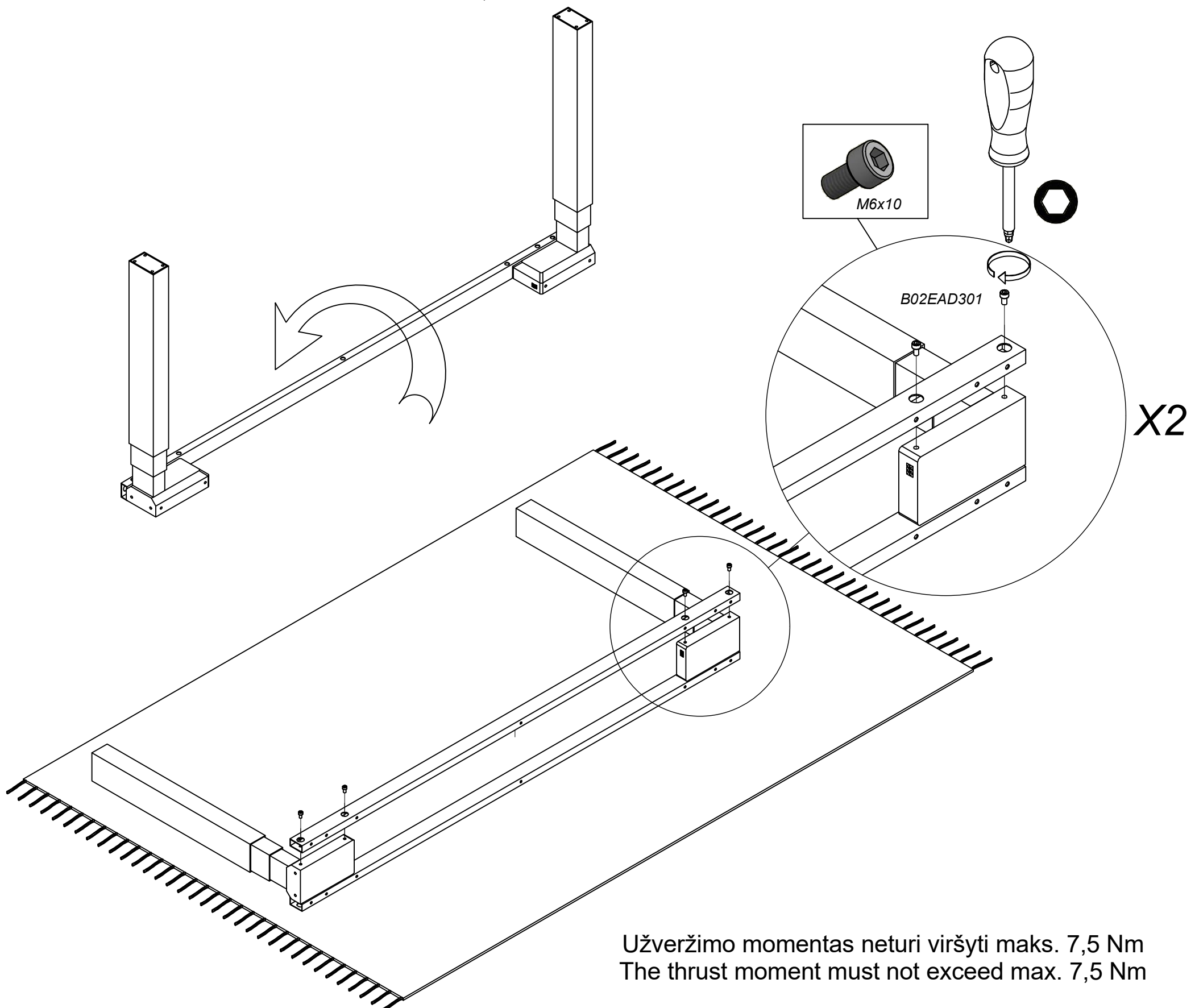

Užveržimo momentas neturi viršyti maks. 7,5 Nm  
 The thrust moment must not exceed max. 7,5 Nm

Užveržimo momentas neturi viršyti maks. 10 Nm  
The thrust moment must not exceed max. 10 Nm

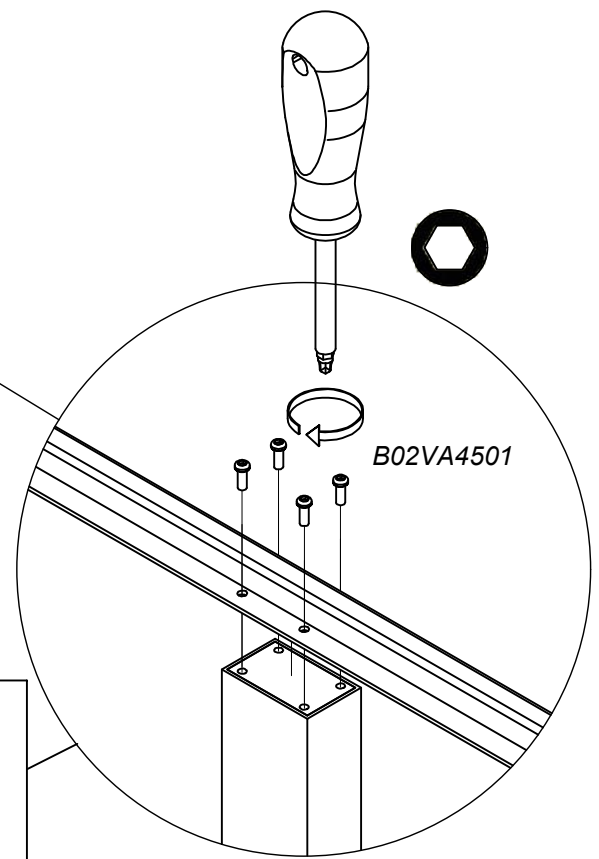
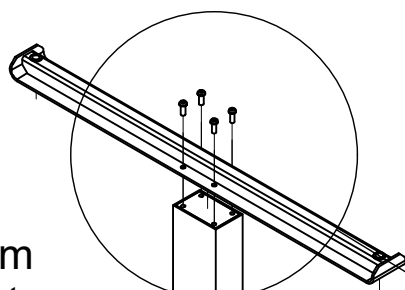
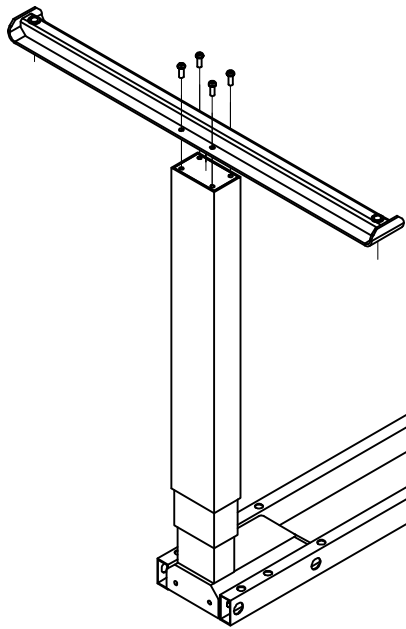

X2



M6x16

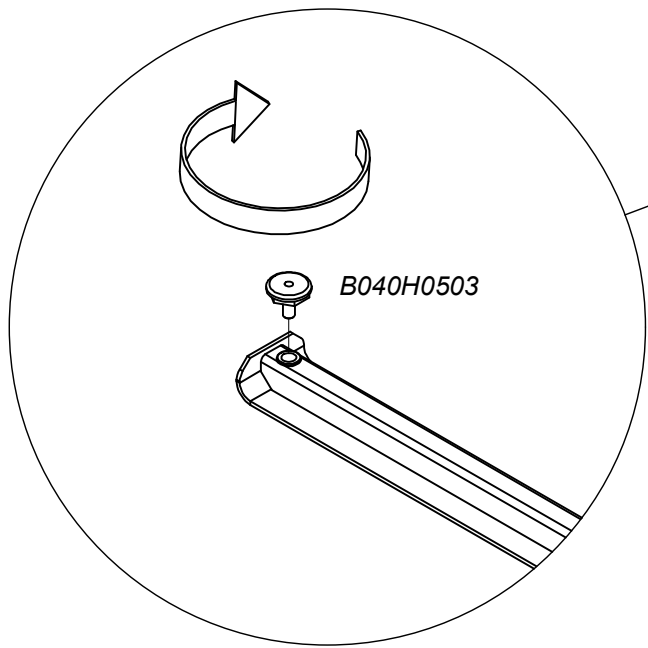
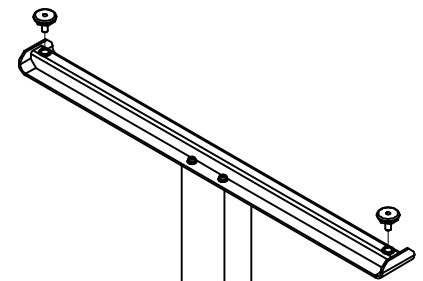

X4

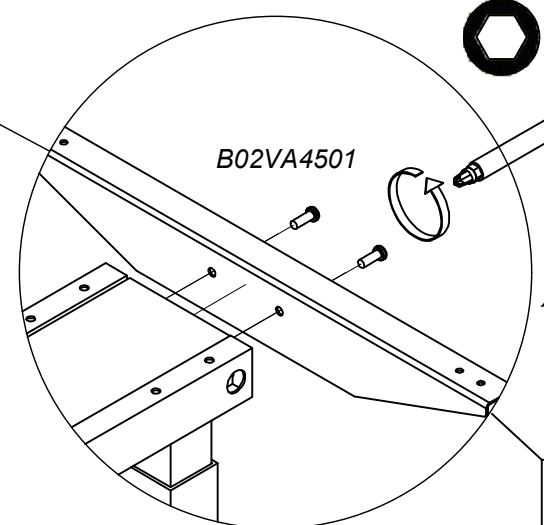
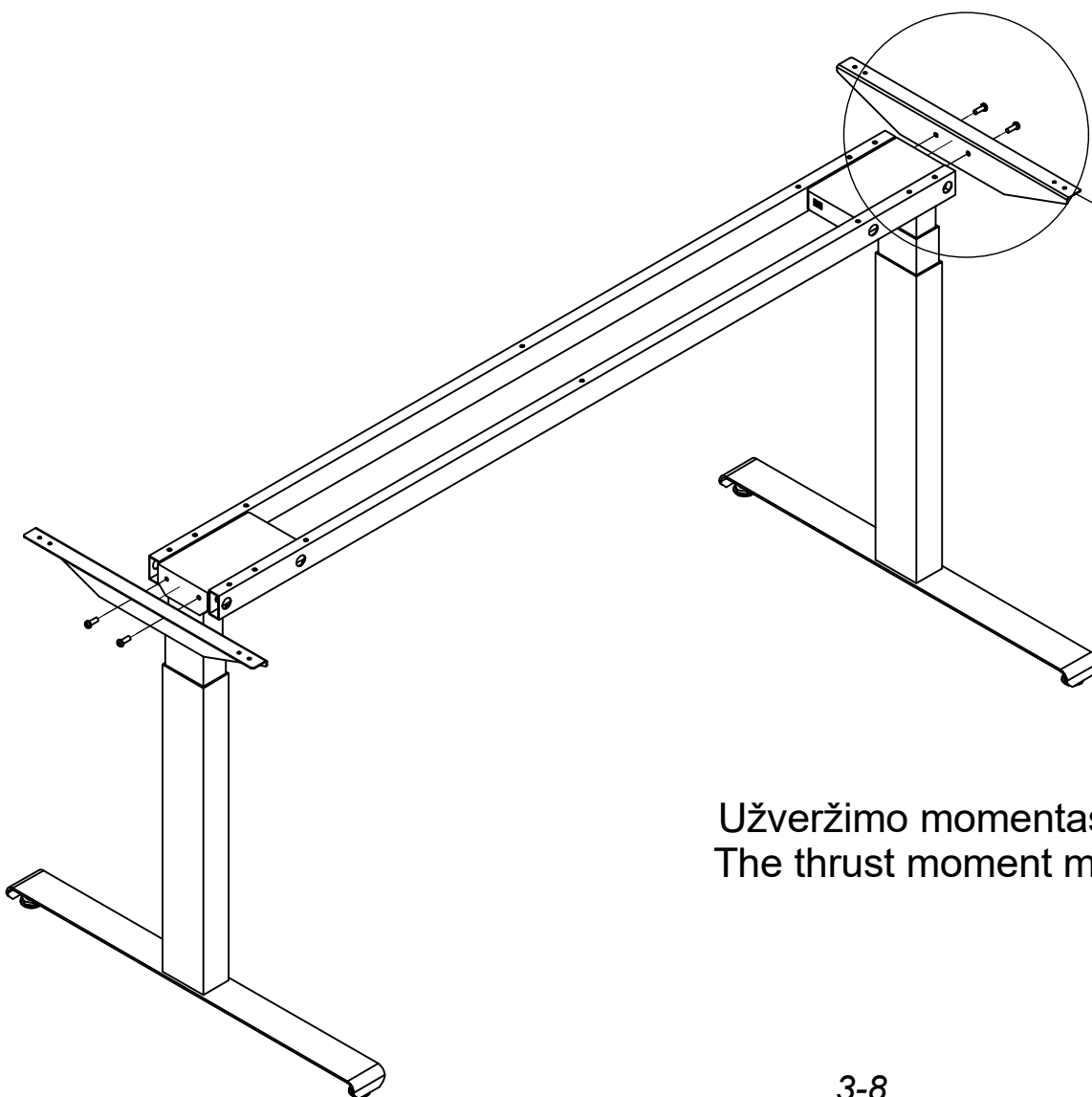
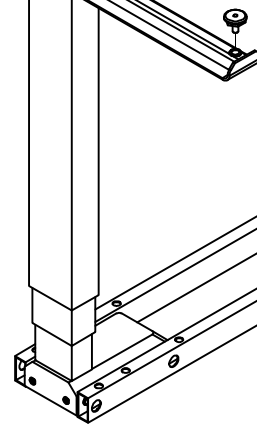
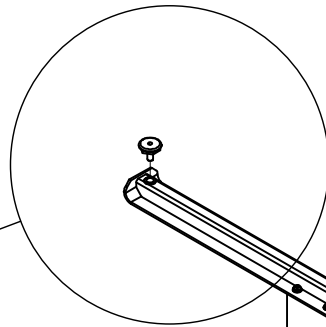

X2



M6x16

Užveržimo momentas neturi viršyti maks. 7,5 Nm  
The thrust moment must not exceed max. 7,5 Nm

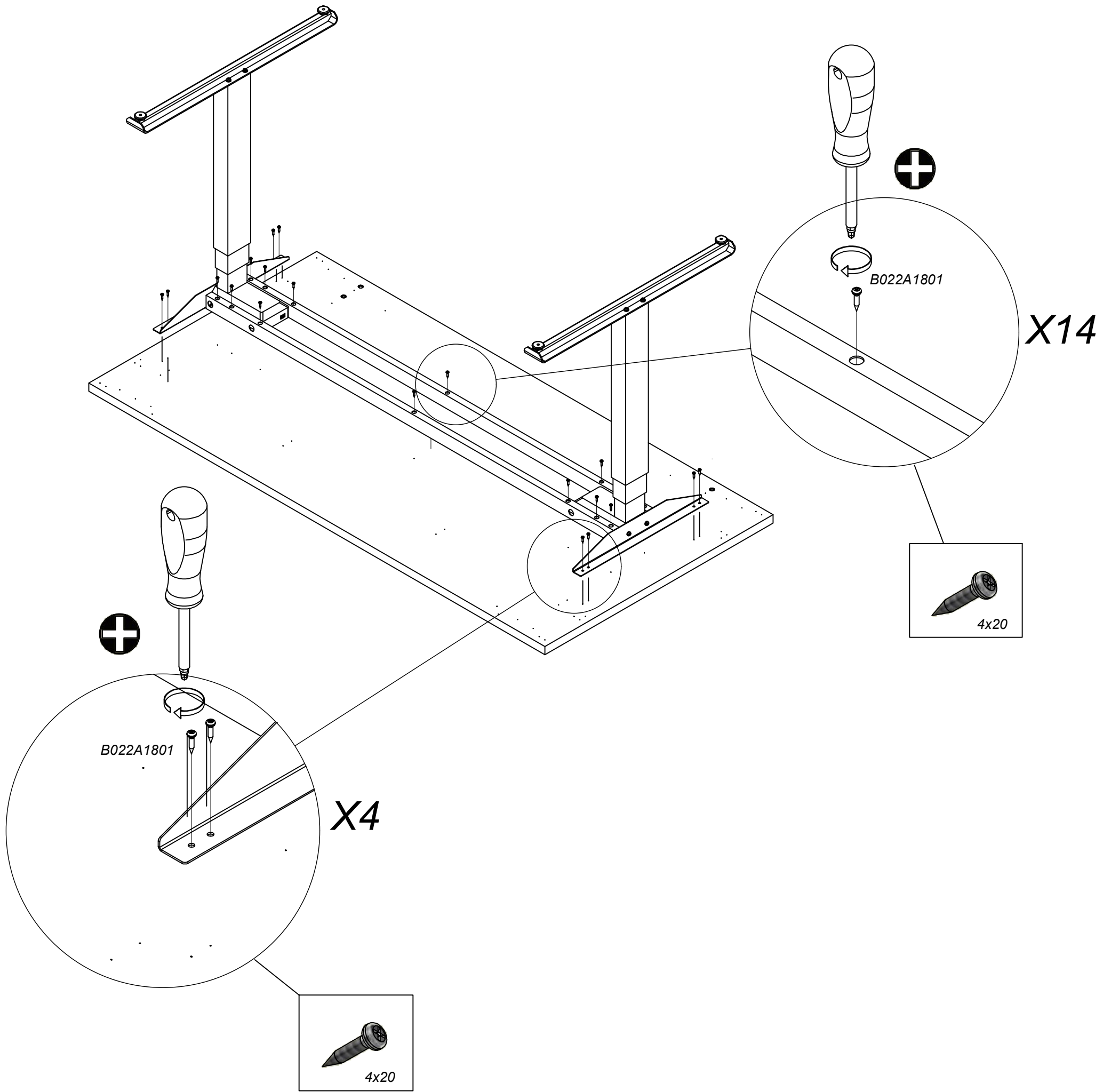

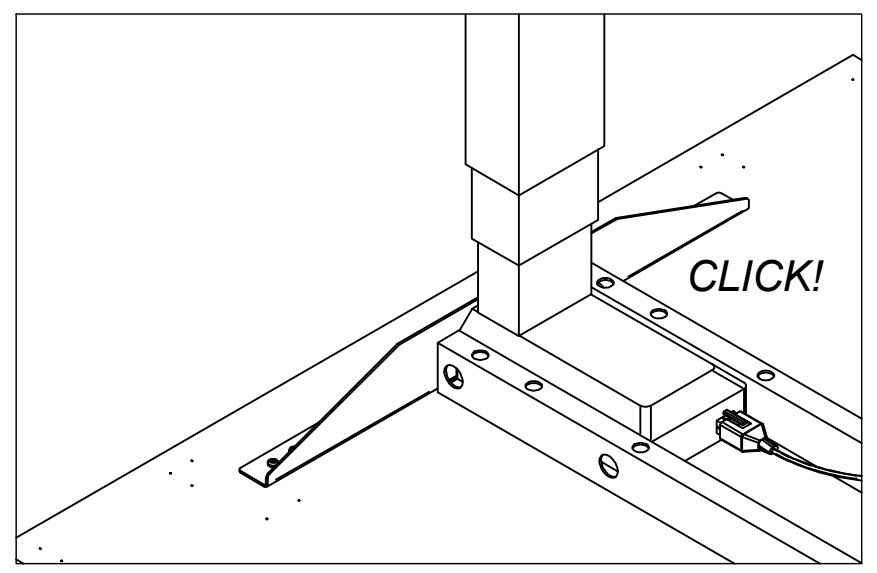
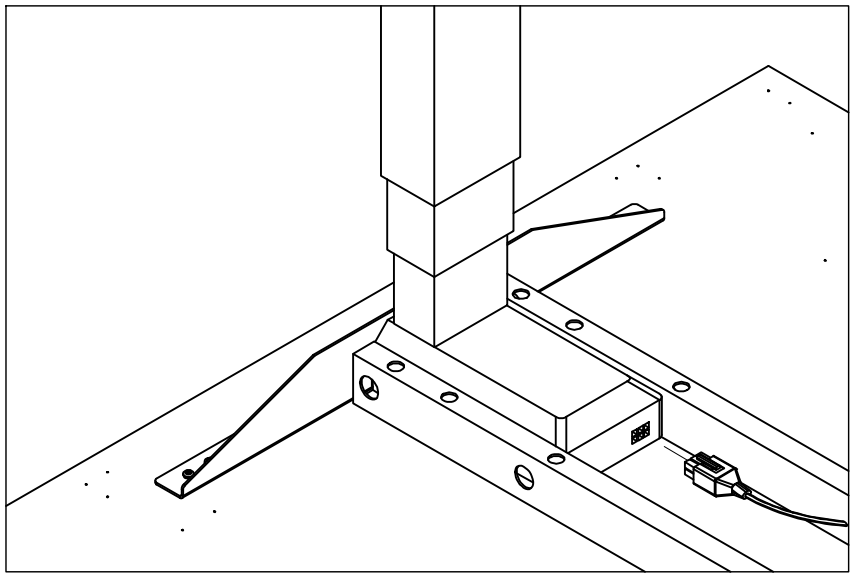
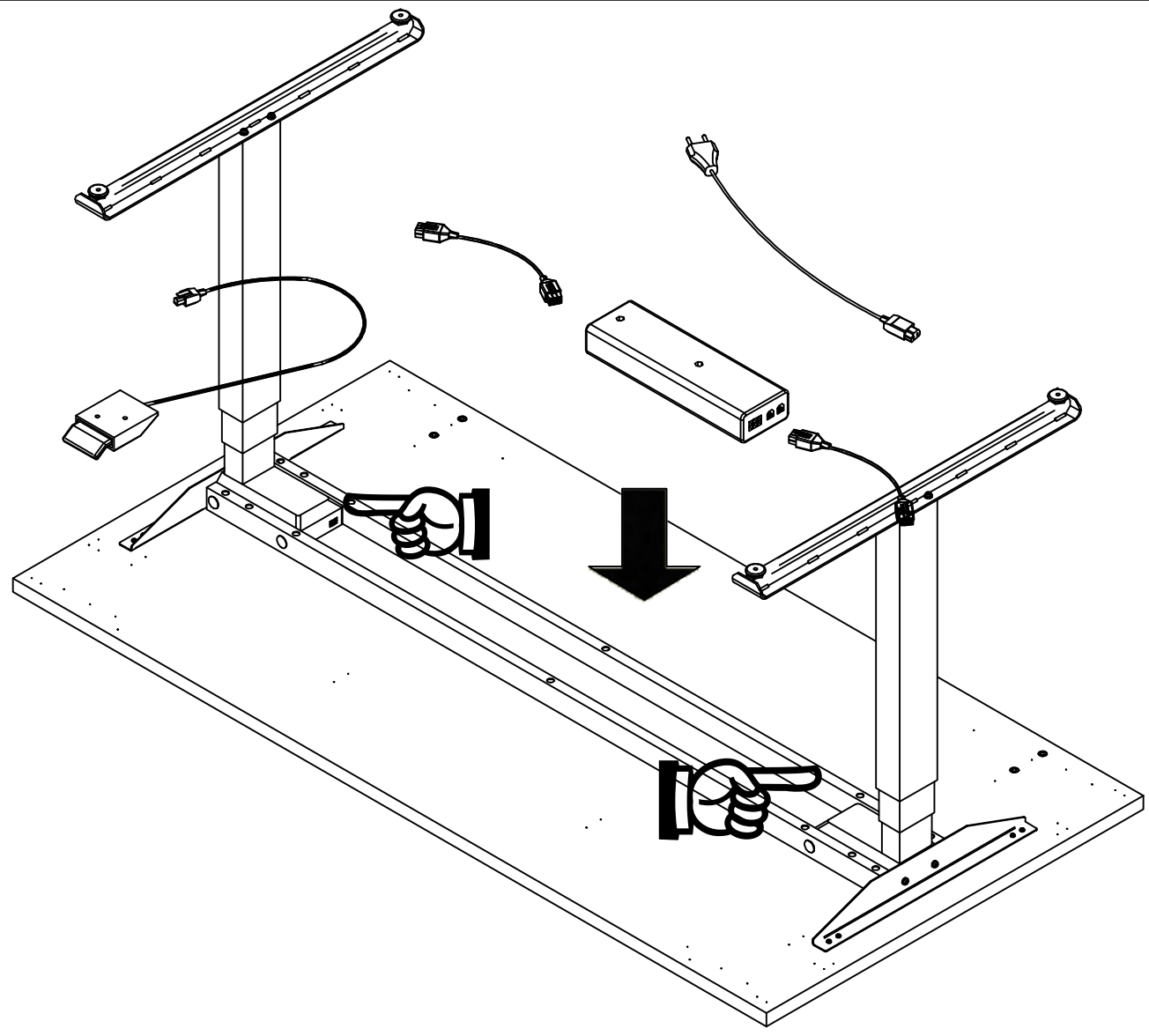
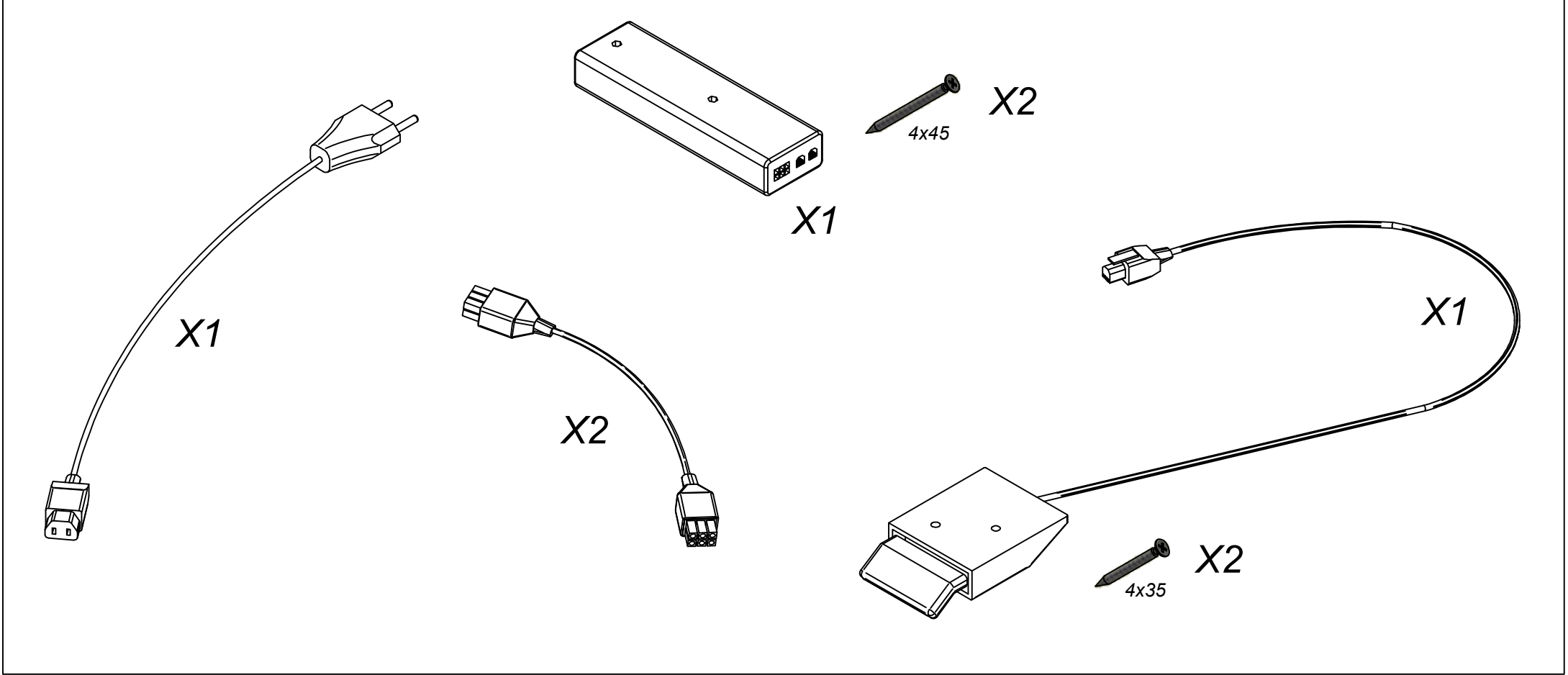

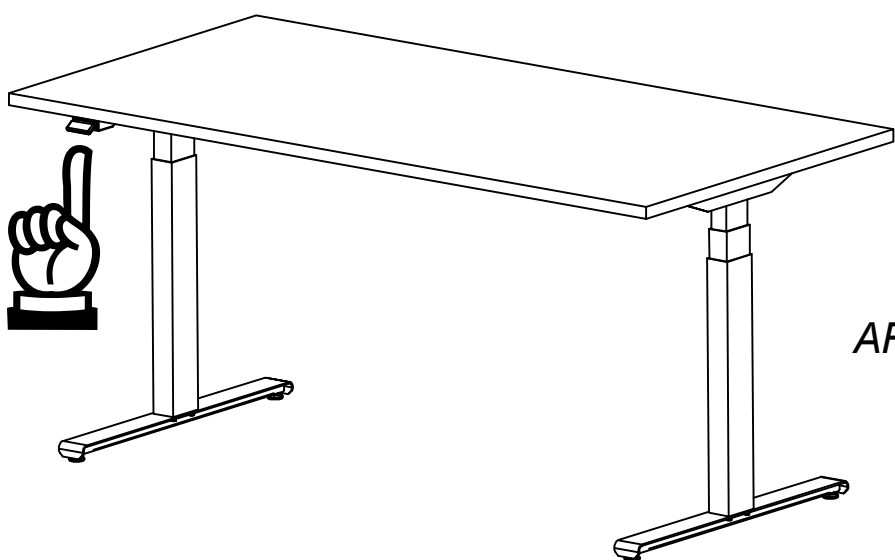
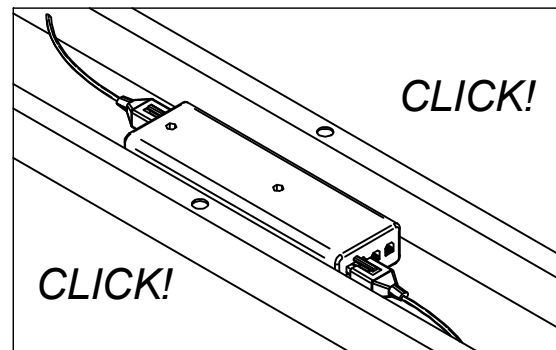
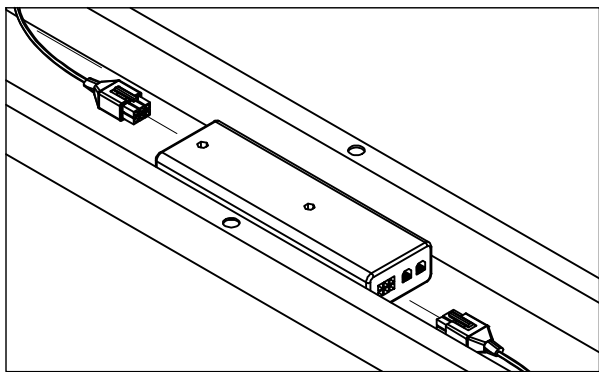
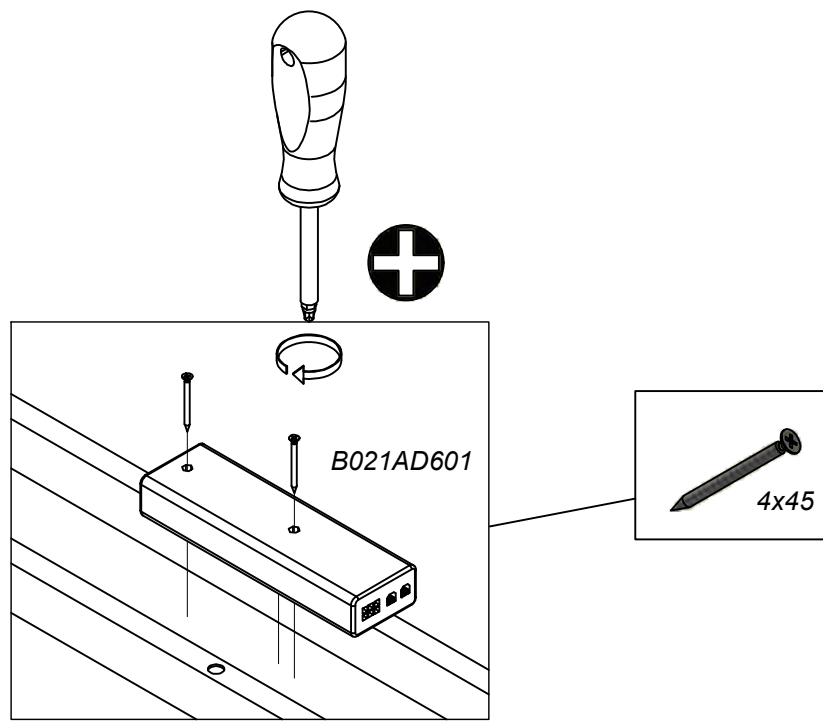

ARBA/OR

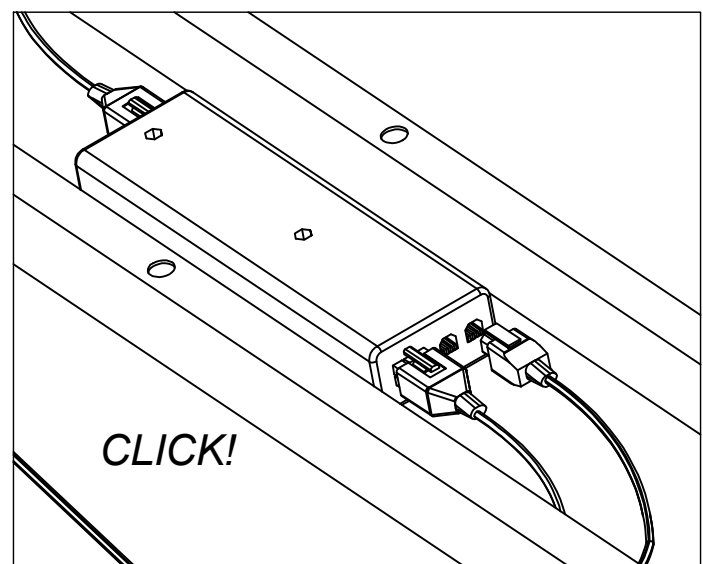
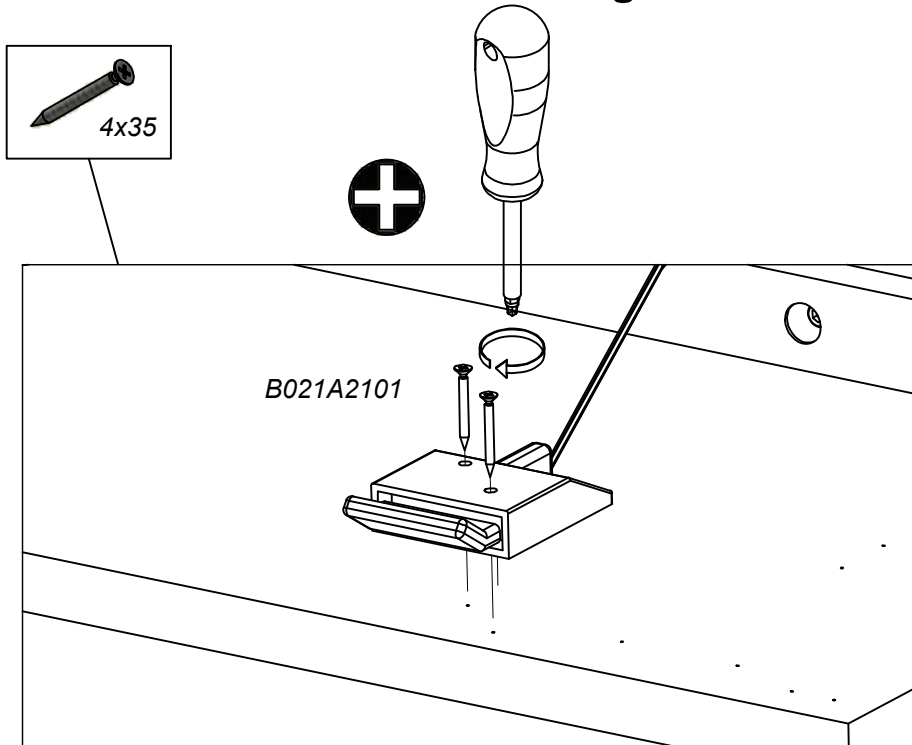
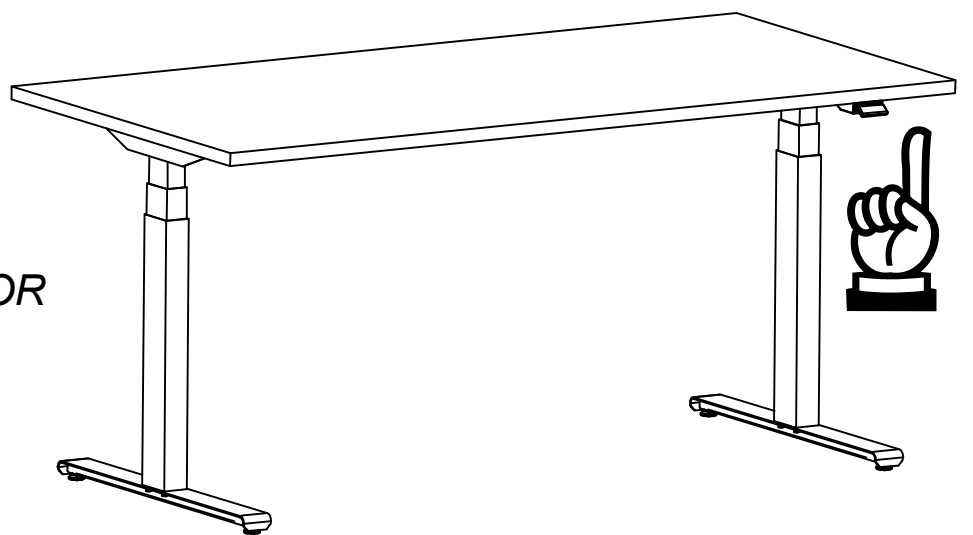

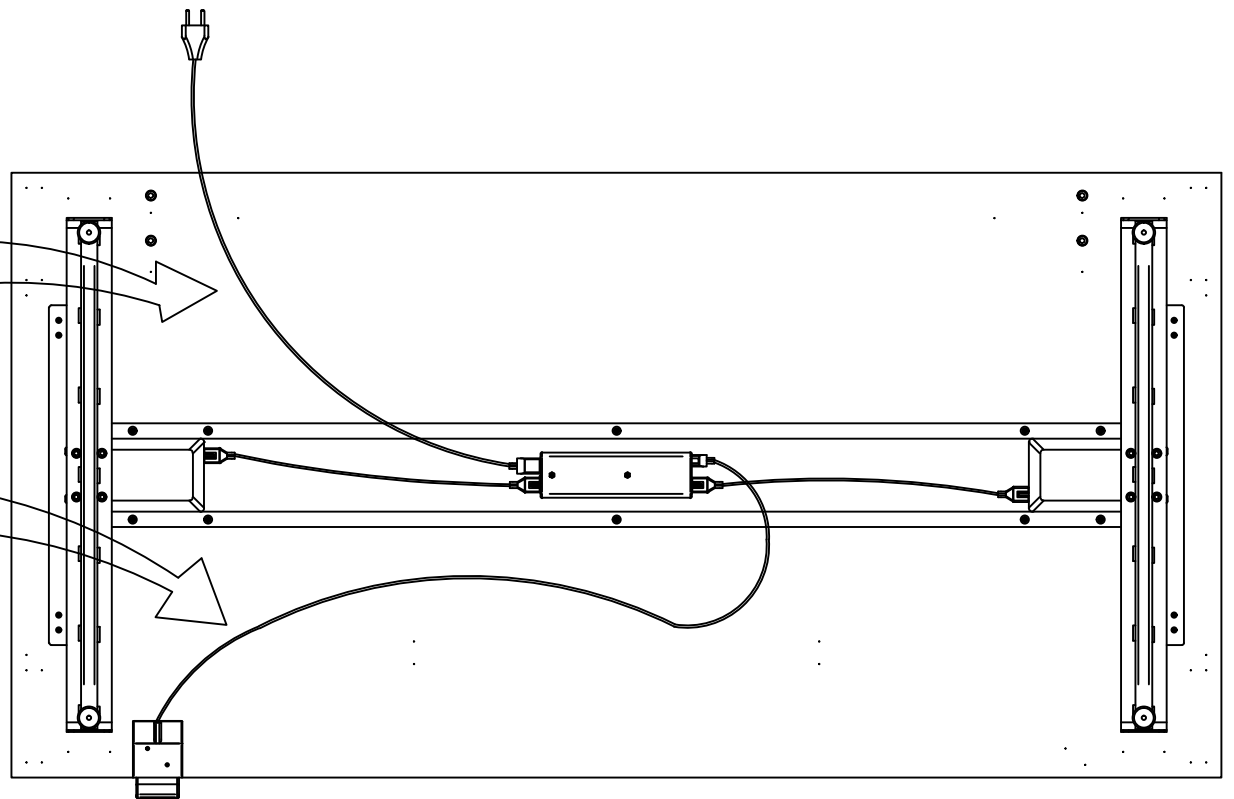
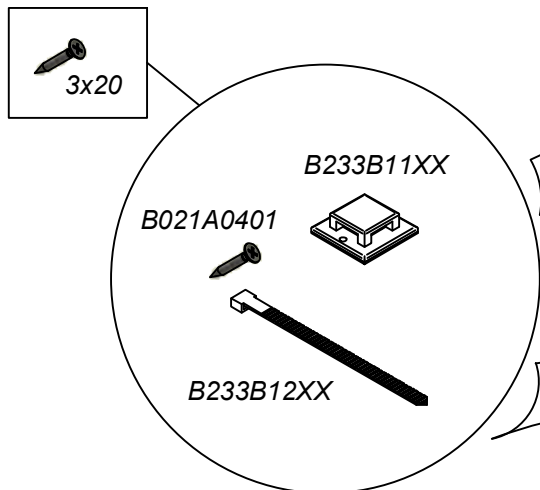
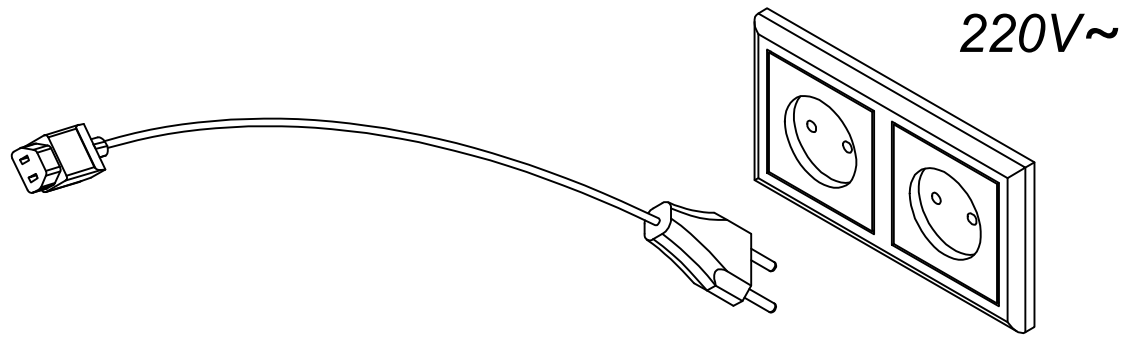
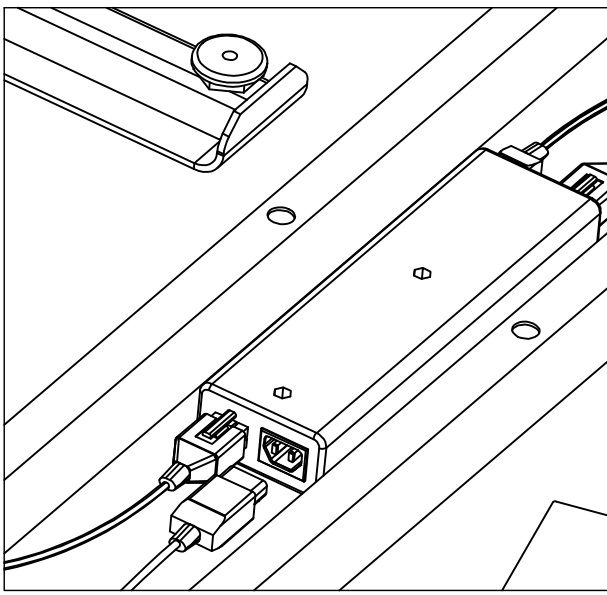

*Dirželiais kabančius  
laidus tvirtiname  
prie stalviršio apačios*

*If it's necessary  
you can fasten  
the wires to  
the table top*

*Išreguluotą stalą įjungiamo  
į elektros tinklą  
Turn the table around to standing  
position and plug the cable in*

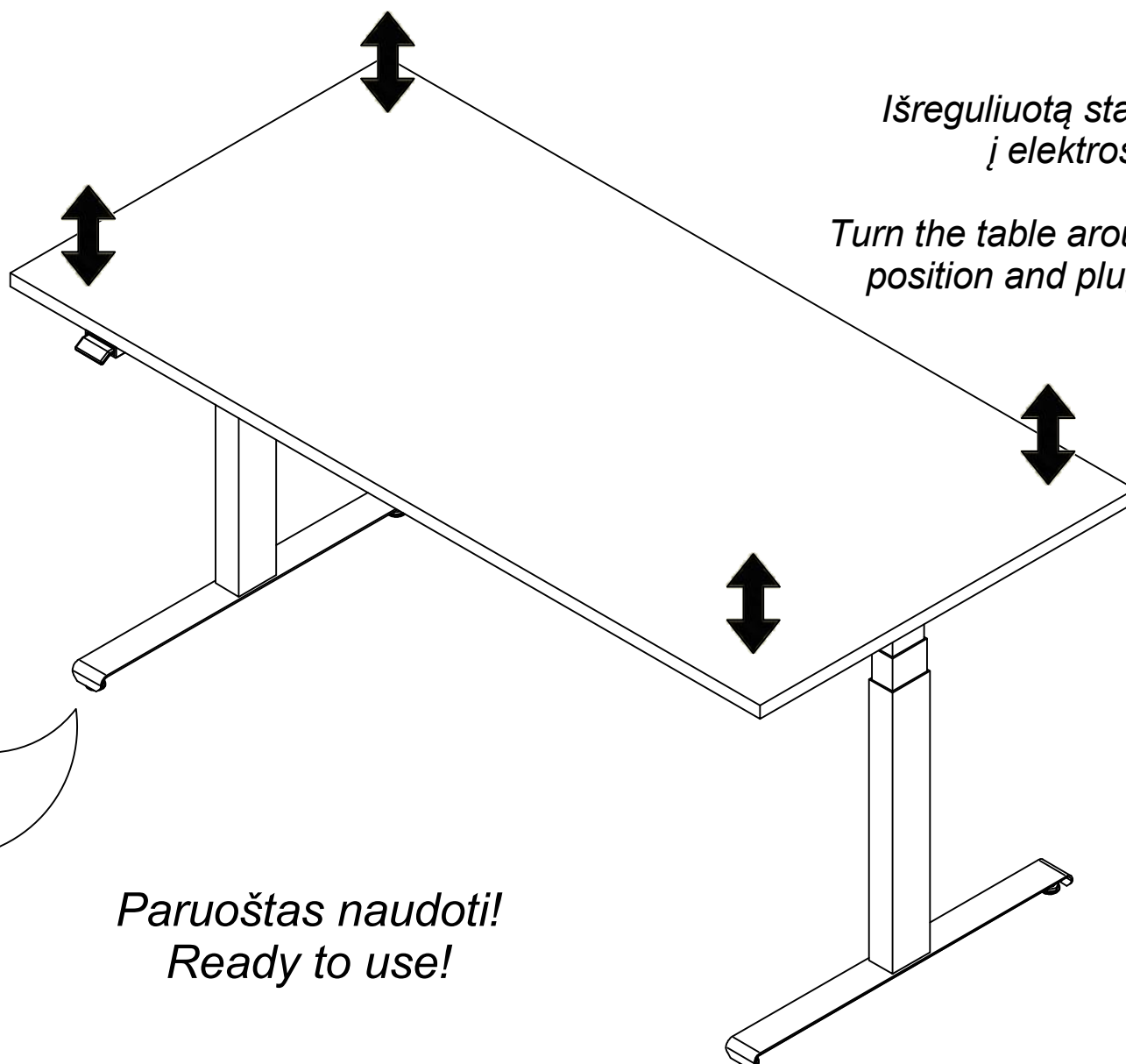

*Paruoštas naudoti!  
Ready to use!*

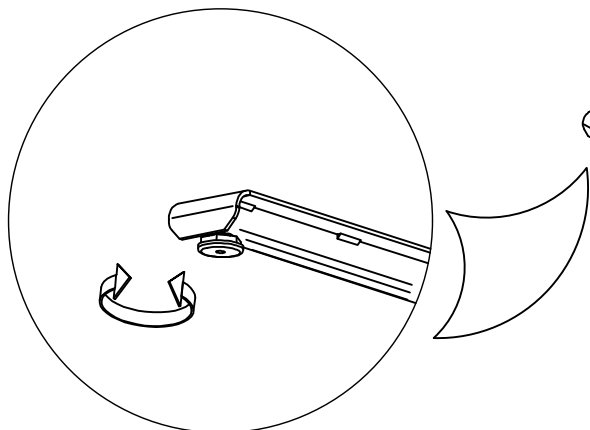

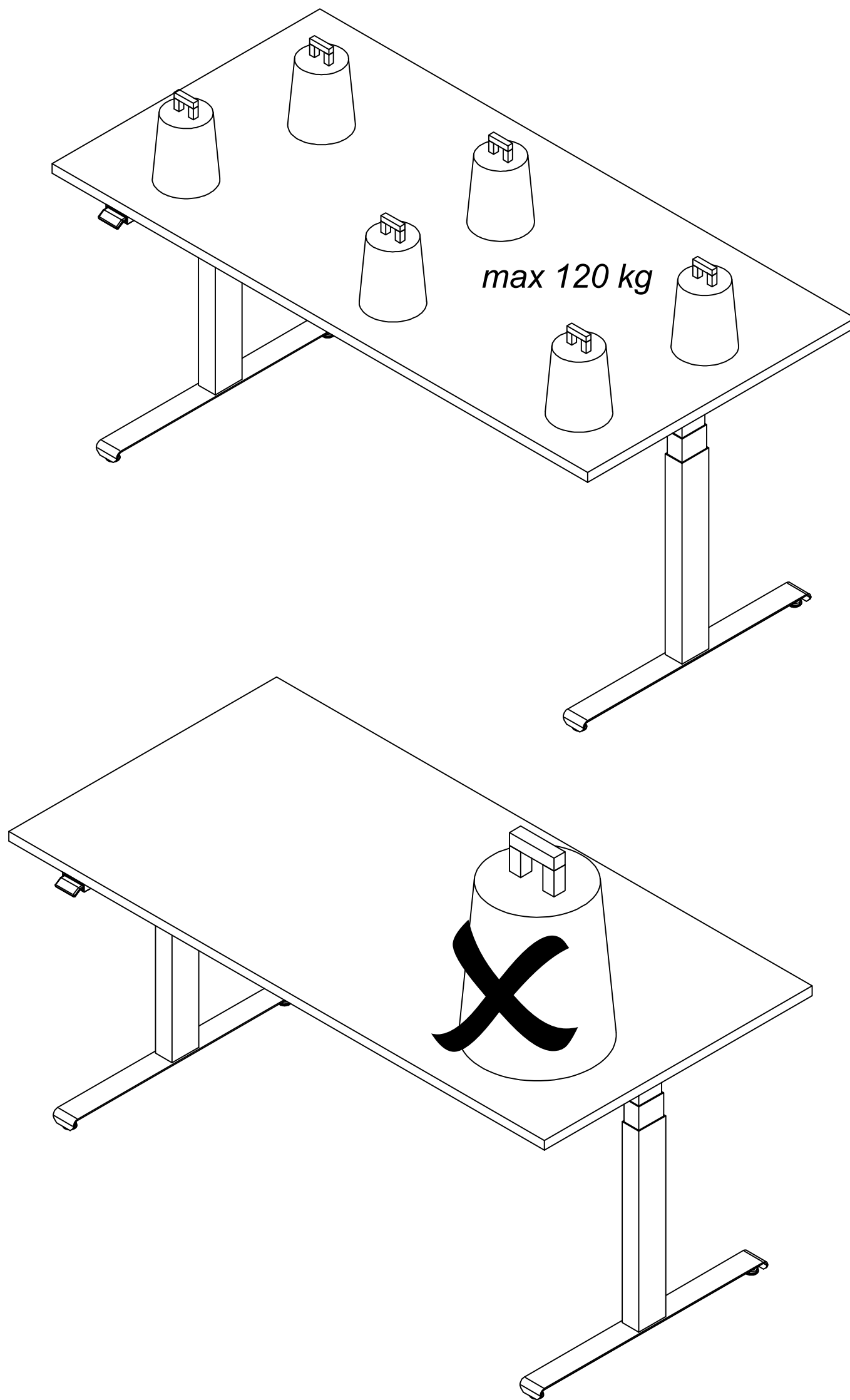

### **DĖMESIO!**

*Prieš pirmą stalo naudojimą ir kiekvieną kartą, kai stalas bus iš naujo įjungtas į elektros tinklą, reikės atlikti šiuos veiksmus:*

- 1. Spauskite mygtuką "žemyn", kol stalas bus visiškai nuleistas. Laikykite nuspaustą mygtuką tol, kol stalas nejudės.*
- 2. Dabar stalą galima pakelti aukštyn.*

### **ATTENTION!**

*Before using the table for the first time and each time the table is reconnected to the power socket, the following steps will be required:*

- 1. Press the "down" key until the desk is lowered completely. Hold the key until the desk no longer moves.*
- 2. Reactivate the down key and hold until the desk no longer moves. Now the desk can be raised.*

